

# SpotSee™ g-View Technical Data

The SpotSee™ g-View impact recorder is a simple solution for monitoring and recording impacts during transportation and storage. The device provides an accurate record of the dates and times at which the user-defined impact threshold is exceeded on the X, Y, and Z axes. With the capacity to record data for 100 over-threshold events per axis, the g-View alerts you when a potentially damaging impact has occurred so you can respond appropriately.

## FEATURES

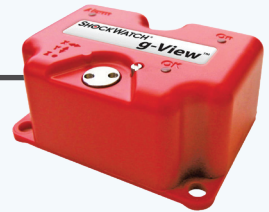

**Sensors to record impact, date, time, internal temperature, axis exceeded, and axis amplitude**

**X, Y and Z impact thresholds can be independently programmed for precise monitoring**

**LED lights for visual notification of threshold breaches**

## CONTENTS

Specifications .....	2
How to Use the ShockWatch g-View .....	2
Best Practices for Mounting .....	3
Drawings .....	4
Accessories & Related Products .....	5
Quality .....	5
Ordering Information .....	5
Technical Support .....	5

## SPECIFICATIONS

### G-VIEW KEY SPECIFICATIONS

<b>Operating Temperature Range</b>	-10°C to 50°C / 14°F to 122°F
<b>Dimensions</b>	70mm x 50mm x 30mm / 2.8in x 2.0in x 1.2in
<b>Weight</b>	81g / 2.56oz
<b>Battery</b>	1 x Alkaline Size AA (replaceable)
<b>Battery Life</b>	Up to 6 months
<b>Case Material</b>	PC / ABS
<b>Sealing</b>	IP65
<b>Accelerometers</b>	Piezo
<b>Shock Range / Cutoff Frequency</b>	10G/25Hz or 25G/40Hz (Factory Set)
<b>Alarm Threshold (% of Range)</b>	20–90% per axis
<b>Shock Accuracy</b>	+/-6% of full scale
<b>Resolution</b>	0.1G
<b>Memory</b>	100 events per axis
<b>Communications</b>	iButton
<b>Software</b>	Functions on Windows 10,8, 7, XP, Vista
<b>Alarm Threshold Breach Indication</b>	LED

## HOW TO USE THE SHOCKWATCH G-VIEW

The g-View attaches directly to the product or packaging and records events above user-defined thresholds, along with the date and time. The information provided by the g-View makes it possible to identify the exact time and date of when potentially damaging mishandling events occurred, as well as temperature. The LED indicator on the unit will indicate if an alarm threshold has been breached on any axis.

Controlled completely through an iButton® interface, users are able to quickly set up and download the g-View through a single-screen software interface. Simply set an impact level threshold, send the setup to the g-View through the iButton interface, and you're ready to record. At the end of a journey, download the collected data with the iButton and load the data to a computer for review and analysis.

### iButton Functions:

**Clock (Black):** Sets the g-View's clock to match the PC's clock

**Setup (Green):** Allows the user to send a new setup to the g-View

**Download (Red):** Enables the user to download a file from the g-View

### Basic Instructions\*:

1. Connect the Clock iButton to the PC via the iButton USB Connection BUS and cable
2. Program the Clock iButton using the g-View software
3. Repeat Steps 1 and 2 with the Setup iButton
4. Place the Clock iButton followed by the Setup iButton on the g-View to transfer data
5. Mount the g-View to the product being monitored
6. Place the Download iButton on the g-View to retrieve event information
7. Connect the Download iButton to the PC via the iButton USB Connection BUS and cable for analysis

\*Please refer to the manual for full details.

## BEST PRACTICES FOR MOUNTING

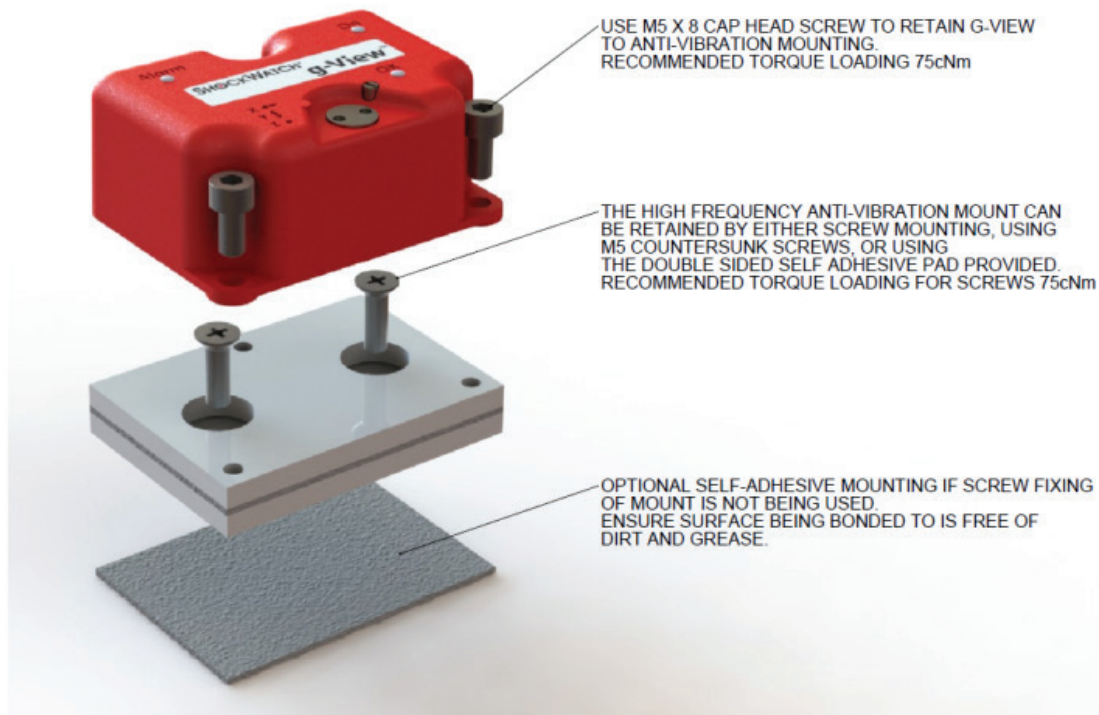

## DRAWINGS

### g-View

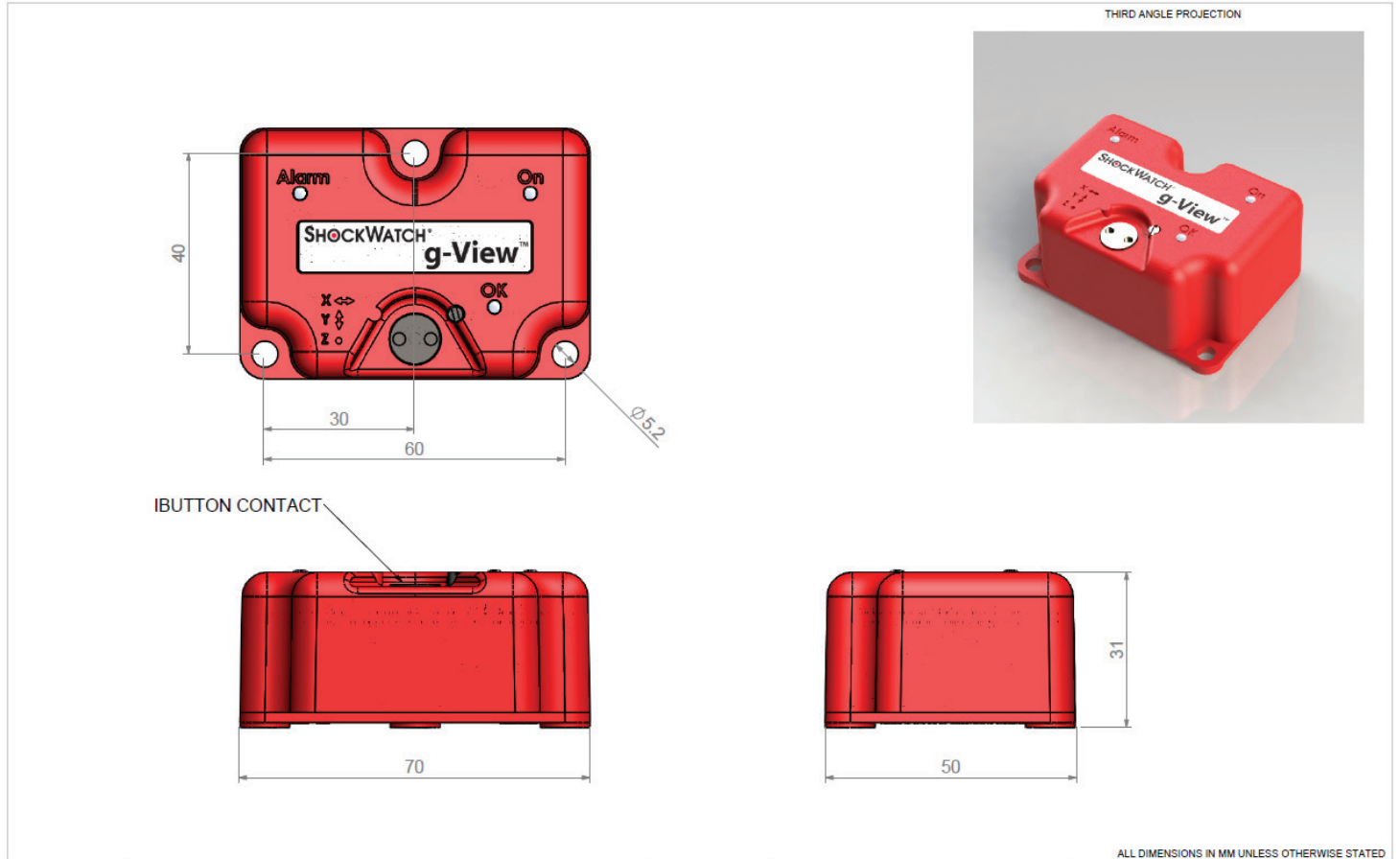

### Mounting Plate

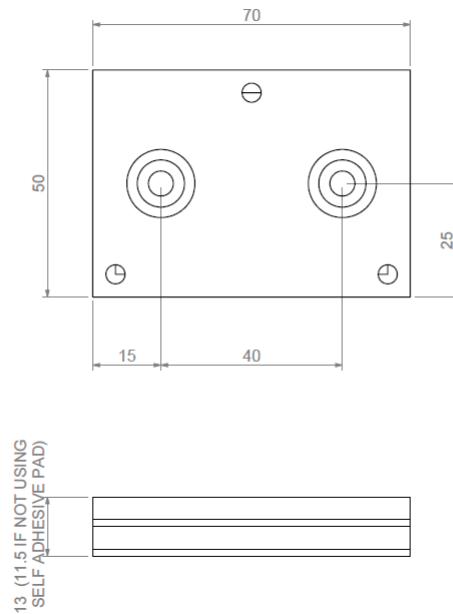

## ACCESSORIES & RELATED PRODUCTS

New users of the g-View are required to purchase a kit in order to get all of the necessary iButton communication accessories and software licenses to correctly operate the g-View. The kit contains the following items (USB drive containing software and manual; Quick Start User Manual; iButton Set: download, setup, clock; 1 iButton USB Connection BUS and Cable; 1 AA Alkaline Battery). Additional iButtons and Mounting Kits may be ordered separately.

## QUALITY

This g-View impact recorder is compliant with the essential requirements and other relevant provisions of directives, ETSI EN 301 489, EN 61326, FCC Rules CFR47 Parts 15 and RTCA/DO160D. Copies of all of these Declarations of Conformity are available upon request.

## ORDERING INFORMATION

Part Number	Description
GV11025	g-View 10g/25Hz Impact Monitor
GV12540	g-View 25g/40Hz Impact Monitor
GV550	g-View Communication Kit
GV500	g-View iButton Set
GV429	g-View Clock iButton
GV428	g-View Setup iButton
GV427	g-View Download iButton
GV10GM	Mounting Kit for g-View 10g/25Hz

## TECHNICAL SUPPORT

If you are unsure of how to use or interpret the g-View impact recorder, please contact SpotSee Technical Support by visiting [spotsee.io/contact](http://spotsee.io/contact) for the latest contact information.